

X/F-Chair

Created for the lightly furnished room or business lounge and designed to appear as a sculpture that with its transparent design, both stands out and let the room to speak for itself.

The chair basically consists of two frames - a leg-frame and a seat-frame - with the seat attached to the legs separated by a small round stick, making the effect as if the seat is floating in the air.

The design is inspired by the "funkis" style and designs by Mies van der Rohe, Poul Kjærholm, Jørgen Høj and Hans J Wegner among others. Here with the simplicity of the industrial design transformed into a light wooden design with rounded edges and craftsmanship based on proud Danish furniture joinery traditions.

The dimensions of the chair are made on a self-made formula contracted as an abstract of the anatomical laws described and drawn by Leonard Da Vinci in "The Vitruvian Man". The length and height of the seat are based on the length of the femur and spine of an average man and a woman, while the angle of the backrest is carefully adjusted to fit the inclination and shape of where the spine and shoulder blades meets, ensuring that the head neither falls backwards nor forwards when sitting in the chair.

The legs of the X-version are deliberately placed above and parallel to the level of the seat (see the red dotted line on illustration below), thereby visually appearing as a natural rounded handle for the user when entering and leaving the chair.

X/F-Chair is produced in natural materials - oak with hemp-cords - and assembled with "mortise-and-tenon joints" and wells as bladed joints with internal grooves and tenons (A). The wood is milled and assembled while it is very dry, where recesses and tenons ensure that no cracks will occur when the chair is later affected by fluctuating humidity.

It is glued and thus assembled totally without use of screws or nails (some exceptions on the natural materials are made on the upholstered versions where foam and staples are used).

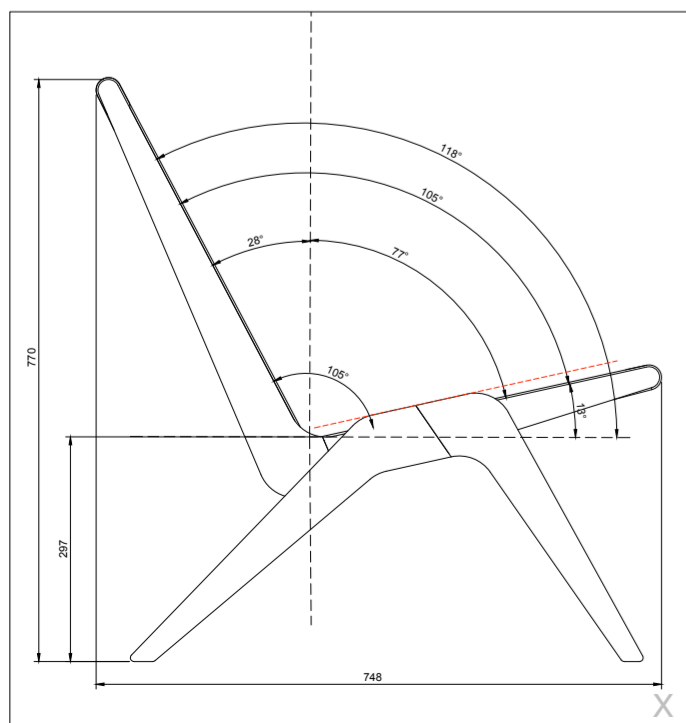
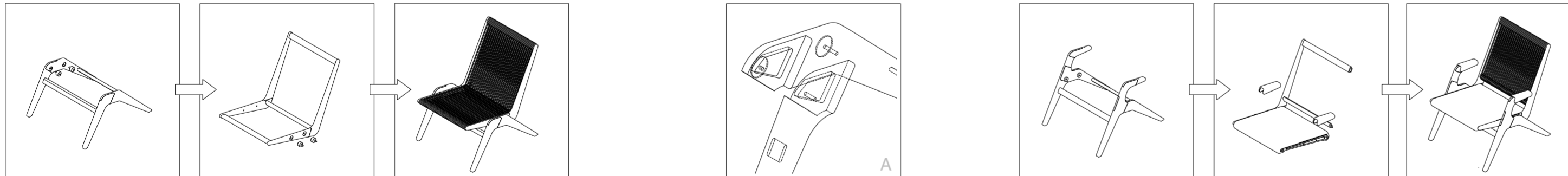

Modularity and JIT as keywords

The front part of the leg-frame can either be mounted with - or without armrests (X or F).

The armrests on F are designed as an interchangeable part of the front-leg in the production phase. The height of the armrest is suited for a position sitting with a book or newspaper in the lap, and the somewhat alternative attachment as a part of the front-leg, is still carefully placed in reclined position to the seat-frame. This ensures that the user can sit in a sideways position.

The seat-frame can be mounted with either hemp cords or with a padded inserted frame - or a combination of the two (variant with padded back not shown).

The chair can thus be regarded as a concept designed with individual taste and needs - as well as with flexible Just-In-Time production - in mind.

